

Mixed harvesters with front umbrella

Serie 100 for dry nuts and olives

Standard equipment:

- › Simultaneous opening movement of umbrella and vibrating heads.
- › Independent regulation of the fold/ unfold speed of the umbrella.
- › High pressure hydraulic system with:
 - › The orbital vibration block is reversible in two directions.
 - › Vibration brake.
 - › Self-tightening of the vibrating head while vibrating.
- › Cover set for hollow peeler standard
- › Monomass vibrating head with elevation and transversal orientation.
- › Rear hydraulic central hitched on the 3 points of the tractor, quick hydraulic plugs, counter-weight, visual gauge for the level and temperature of the oil, thermostat, cooling system, suction and return filters.
- › Peelers with independent regulation.
- › In-cab electronic control box.
- › Quick system to hitch/unhitch quickly the harvesting box (according to the models).
- › Supplement 4 mass MIX.
- › Supplement 5 mass MIX.
- › PTO SHAFT 1000 r.p.m.
- › Optimal working revolutions: 880 r.p.m.
- › Prepared for the collection of nuts.

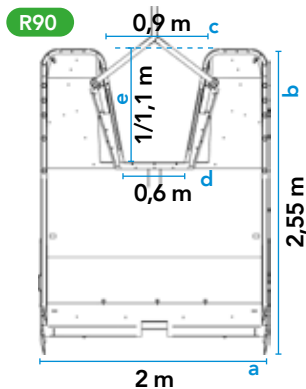
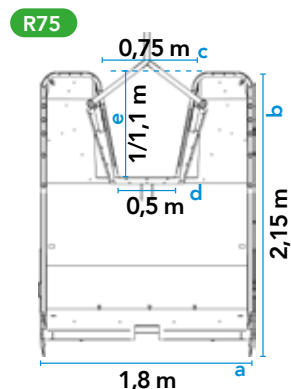

- a: Total width
- b: Total length
- c: Tree entrance opening
- d: Interior width
- e: Interior length

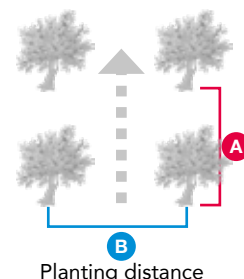

CODE	MODEL	QUICK UNHITCH OF BOX	EXTEN. VIBR. H. 400 mm	BOX DIMENSIONS (m)							Ø UMBRELLA (m)	POWER (CV)	MINIM. PLANTING DISTANCE (m)*	
				Adjust. grid	Peelers	a	b	c	d	e			A	B
1041030002	R90 E	x	x	x	2	2	2,55	0,9	0,6	1,1	7	70	6	7
1041010046	R75	x	x	•	x	1,8	2,15	0,75	0,5	1,1	6,5	80	5	6
1041030001	R75 MIX	x	x	•	2	1,8	2,15	0,75	0,5	1	6,5	80	5	6
1041030003	R90 MIX	x	x	•	2	2	2,55	0,9	0,6	1,1	7	90	6	7
1041030005	R90 MIX EXT	x	•	•	2	2	2,55	0,9	0,6	1,1	7	90	6	7
1041030004	R90 MIX ENG RAP	•	x	•	2	2	2,55	0,9	0,6	1,1	7	90	6	7
1041030006	R90 MIX EXT ENG RAP	•	•	•	2	2	2,55	0,9	0,6	1,1	7	90	6	7

• Available | x: Not available | (*) Minimum advisable planting distance

Options



Protection piece of the hydraulic cylinder Mix

CODE
2041010006



Sequencer harvester

CODE
2049010004



Tightening vibrating head adjustment kit for R75 MIX and R90 MIX

CODE
2041030002



Increment per joystick

CODE
2049000001



Kit "young olive trees" for R75 MIX

CODE
2041030009



Kit "young olive trees" for R90 MIX

CODE
2041030010



Deck support increment mounted for R75 MIX

CODE
2041070012



Deck support increment mounted for R90 MIX

CODE
2041040004



Kit to guide to the trunk for R75 MIX

CODE
2041050011

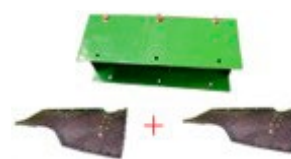

Kit to guide to the trunk for R90 MIX

CODE
2041010001



Replacement of standard mallets by mallets with soft clamp in R75 MIX

CODE
2041030012



Replacement of standard mallets by mallets with soft clamp in R90 MIX

CODE
2041060003



Replacement of the standard skirt by soft skirt in equipment R75 MIX

CODE
2041030013



Replacement of the standard skirt by soft skirt in equipment R90 MIX

CODE
2041030011



In-cab control box MIX with potentiometer

- › For almonds, regulation of the working speed of the peeler from the cabin of the tractor.
- › For olives, regulation of additional vibration from the cabin of the tractor.

CODE
2041030003



Lateral movement of umbrella R75 MIX

CODE
2041050003